

# **Instructions and Operations Manual for SPR-Series Manual Pressure Relief Valve**



Read and understand this manual prior to installing, operating or servicing this valve



*The Right Connection®*

**Dixon Sanitary**

N25 W23040 Paul Road • Pewaukee, WI 53072

ph: 800.789.1718 • fx: 800.789.4046

[dixonvalve.com](http://dixonvalve.com)

# Introduction

This manual contains installation, operation, cleaning, repair instructions, model numbering structure and a parts list for the Dixon Sanitary SPR-Series Manual Pressure Relief Valves. Please read and understand this manual prior to installing, operating or servicing this valve.

The Dixon Sanitary SPR-Series Manual Pressure Relief Valve is a compact manually adjustable clean-out-of-place valve assembly used in sanitary process systems to protect pressure sensitive equipment. The valve utilizes three different springs with three unique spring constants to cover set pressure ranges of 10-50 PSI, 50-100 PSI or 100-300 PSI.

The high-quality valve body is precision machined from solid 316L bar. Valve bodies are available in two different body configurations with a variety of different connection options.

---

## Table of Contents

|                                 |     |
|---------------------------------|-----|
| Safety .....                    | 3   |
| Care of Stainless Steel .....   | 4   |
| Technical Specifications .....  | 5   |
| Installation and Start-Up ..... | 6-7 |
| General Maintenance .....       | 8   |
| Assembly and Disassembly.....   | 9   |
| Dimensions.....                 | 10  |
| Bill of Materials .....         | 11  |
| Troubleshooting.....            | 12  |
| Warranty.....                   | 13  |

## Safety Information

### Do's and Don'ts

- Do read and understand these instructions before installing or using the SPR-Series pressure relief valve.
- Do use Dixon spare parts when replacing components of the relief valve.
- Do Not attempt to service the relief valve while under pressure.
- Do Not place the relief valve in an application where the service ratings are exceeded.
- Do Not attempt to modify the relief valve assembly as it may compromise the integrity of the assembly and will void all warranties.

### Safety Precautions When Installing Relief Valve

- Do relieve product line pressure before attempting to install relief valve.
- Do install discharge piping that allows discharged product to flow safely to a drain or bypass.
- Do Not install a damaged relief valve assembly.
- Do Not install relief valve between damaged clamp ferrules.

### Safety Precautions When Relief Valve is in Operation

- Do monitor the relief valve assembly for any sign of leakage.
- Do check all clamp assemblies often to ensure that they have not loosened from vibration.
- Do Not stand in the vicinity of the discharge outlet while the relief valve is in operation.
- Do Not attempt to loosen any clamp assemblies while the relief valve is in operation.
- Do Not attempt to perform any type of service or adjustment to the relief valve during operation.

### Safety Precautions When Servicing the Relief Valve

- Do drain piping completely before servicing.
- Do vent line to relieve any pressure.
- Do relieve spring force before attempting to remove body clamp.
- Do use caution and wear protective clothing if relief valve has been used in applications using acids or other chemicals that may be harmful.

## Care of Stainless Steel

The stainless steel components in Dixon Sanitary equipment are machined, welded and assembled by skilled craftsmen using manufacturing methods that preserve the corrosion-resistant quality of the stainless steel.

Retention of corrosion-resistant qualities under processing conditions requires regular attention to the precautions listed below.

1. Regularly check all electrical devices connected to the equipment for stray currents caused by improper grounding, damaged insulation or other defects. Corrosion: Pitting often occurs when stray currents come in contact with moist stainless steel.
2. Never leave rubber mats, fittings, wrenches, etc. in contact with stainless steel. Corrosion: Pitting or galvanic action. Objects retard complete drying, preventing air from reforming the protective oxide film. Galvanic corrosion occurs when two dissimilar metals touch when wet.
3. Immediately rinse equipment after use with warm water until the rinse water is clear. Clean the equipment (manual or CIP) as soon as possible after rinsing. Corrosion: discoloration, deposits, pitting. Product deposits often cause pitting beneath the particles.
4. Use only recommended cleaning compounds. Purchase chemicals from reputable and responsible chemical manufacturers familiar with stainless steel processing equipment, they continuously check the effects of their products on stainless steel.
5. Use cleaning chemicals exactly as specified by the manufacturer. Do not use excessive concentrations, temperatures or exposure times. Corrosion: Pitting, discoloration, stress cracks. Permanent damage often occurs from excessive chemical concentrations, temperatures or exposure times.
6. For manual cleaning, use only soft non-metallic brushes, sponges or pads. Brush with the grain on polished surfaces, avoid scratching the surface. Corrosion: Pitting, scratches. Metal brushes or sponges will scratch the surface and promote corrosion over a period of time. Metal particles allowed to remain on a stainless steel surface will cause pitting.
7. Use chemical bactericides exactly as prescribed by the chemical manufacturer in concurrence with local health authority. Use the lowest permissible concentration, temperature and exposure time possible. Flush immediately after bacterial treatment. In no case should the solution be in contact with stainless steel more than 20 minutes. Corrosion: Protective film destroyed. Chlorine and other halogen bactericides can destroy the protective film. A few degrees increase in temperature greatly increases chemical activity and accelerates corrosion.
8. Regularly inspect the joints in pipelines. Be sure all connections are tight fitting without binding. Corrosion: Crevice corrosion. Small crevices caused by improperly seated gaskets will promote crevice corrosion. Stainless steel under stress will develop stress cracking especially in the presence of bactericides containing chlorine.
9. Regularly inspect equipment for surface corrosion (i.e. pitting deposits, stress cracks, etc.). If deposit or color corrosion is detected, remove it immediately using mild scouring powder and detergents. Rinse thoroughly and allow to air dry. Review production and cleaning procedures to determine the cause. Note: If corrosion is not removed, the protective film cannot be restored and corrosion will continue at an accelerated rate.

# Technical Specifications

## Specifications:

| Model     | Set Pressure Range (PSI) | Maximum Temperature Operating [Sterilization ‡] |
|-----------|--------------------------|---|
| SPR-TC*1A | 10-50                    | 266°F [300°F]                                   |
| SPR-TC*2A | 0-100                    |   |
| SPR-TC*3A | 0-300                    |   |
| SPR-LC*1A | 10-50                    |   |
| SPR-LC*2A | 0-100                    |   |
| SPR-LC*3A | 0-300                    |   |

\* E = EPDM or V = FKM

‡ Maximum 20 min

## Materials:

- Product contact parts: AISI 316L Stainless Steel
- Product contact elastomers: EPDM or FKM
- Non-Product contact components: 304 Stainless Steel
- Finish: 32 R<sub>a</sub> on all product contact surfaces, other finishes available

## Connections:

- Clamp (Standard)
- Bevel Seat, I-Line, and Weld ends available

## Sizes:

- 1½" and 2"

# Installation & Start Up

## Unpacking:

Carefully unpack all parts of the valve and inspect for damage that may have occurred during shipment. Report any damage to the carrier immediately.

The ports on the valve are protected with a plastic cover. If any covers are missing or damaged, inspect the ports on the valve thoroughly for any damage.

## Tools Needed:

The following items will be needed for the installation.

- Adjustable wrench
- Food grade anti-seize

## Installation Orientation:

The valve should be installed so that the fluid pressure is acting on the valve stem end. The following diagram should be followed when installing the valve for service. **DANGER:** Improper discharge piping from the valve could lead to serious injury. High pressure and potentially high temperature fluid exits the discharge port when valve opens. Piping should be installed so that the discharged product flows safely to a drain.

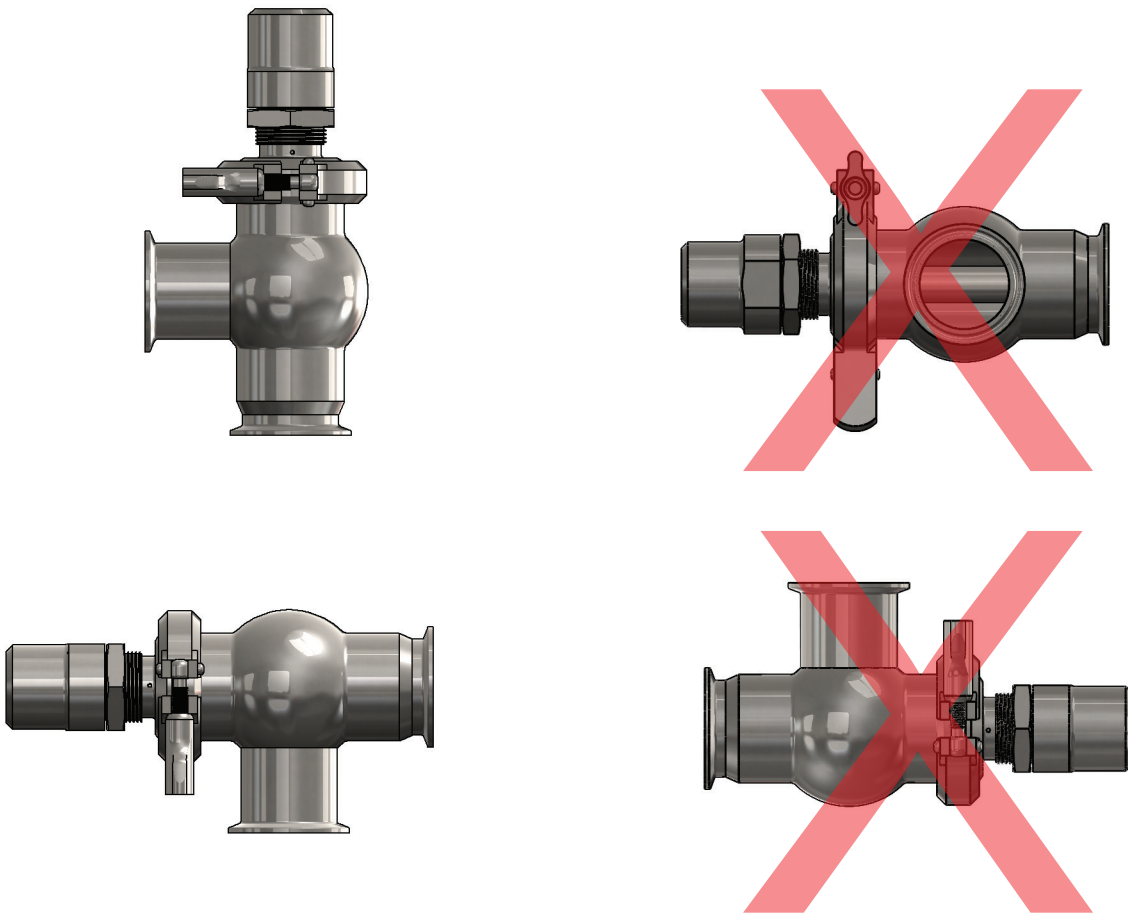

# Installation & Start Up

## Setting Relief Pressure:

1. Identify which spring set the valve utilizes by referring to the tag located on the adjustable cap. Below is an example of the tag that will be located on the valve. There are three separate spring sets available for the SPR-Series pressure relief valve: Spring Set 1 (10-50 PSI), Spring Set 2 (50-100 PSI), and Spring Set 3 (100-300 PSI).



2. Once the spring set has been identified, refer to the set pressure table below to obtain the values needed to calculate the number of turns required for the desired set pressure.

| Spring Set | Maximum Set Pressure (PSI) | PSI / Turn | Turns to Max Set Pressure |
|------------|----------------------------|------------|---------------------------|
| 1          | 50                         | 11         | 4½                        |
| 2          | 100                        | 21         | 4¾                        |
| 3          | 300                        | 105        | 2¾                        |

3. Once the desired set pressure has been determined, divide the set pressure by the PSI/Turn value obtained from the set pressure table. This will yield the number of required turns.
4. Using the numbered marks on the adapter (8) and the mark on the adjustable cap (12) as reference points, turn the adjustable cap (12) the calculated number of turns.
5. Using a pressure gauge on the inlet port of the valve, make any minor adjustments of the cap (12) needed to reach the exact pressure relief point desired.
6. Confirm that the valve functions as desired before installing the valve for service.
7. Tighten the locking nut (9) firmly against the adjustable cap (12) while keeping the adjustable cap stationary to avoid changing the relief pressure set point. Apply food grade anti-seize to the adapter threads if necessary.

## General Maintenance

To ensure that your Dixon SPR-Series pressure relief valve functions as designed, it is important to make sure that it is properly maintained. Only use genuine Dixon replacement parts when replacing any components of the SPR-Series pressure relief valve. DO NOT attempt to modify the valve in any way. Doing so will void all warranties and could result in injury.

### Cleaning the valve:

1. Refer to the disassembly section of the manual and follow instructions to remove all product contact components of the valve.
2. Inspect the product contact components of the valve for any signs of possible damage. Replace components as necessary.
3. Clean all surfaces of the product contact components by manually brushing in a bath of cleaning solution (**acid detergents or simple alkaline soda type detergents**).
4. After cleaning, rinse all components thoroughly with water.

**Note: Seat seal (2) must be replaced after removal**

5. Refer to the assembly section of the manual and follow instructions to properly reassemble the valve.
6. Refer to the installation and start-up section of the manual for instructions on setting the valves relief pressure.



# Assembly and Disassembly Instructions

## Assembly:

1. Take new seat seal (2) and install on the valve stem (3), making sure not to roll the seat seal.
2. Place the body gasket (5) on the top inside lip of the valve body (1).
3. Loosely place the valve stem and seat seal assembly (2 & 3) in the valve body (1).
4. Slide the stainless stem holder (6) over the valve stem assembly (2 & 3).
5. Apply food grade lubricant to the stem O-ring (7), and slide the O-ring over the stem (3) and press down securely into groove in the stem holder (6).
6. Slide the adapter (8) over the valve stem (3) and secure the adapter to the valve body (1) using the clamp (13).
7. Place the washer (4) in the bottom of the adapter (8).
8. Place the spring (10) on top of the washer (4) inside the adapter (8).
9. Take the top cap (11) and place it on the spring (10).
10. Apply food grade anti-seize to the threads on the adapter (8).
11. Thread on the locking nut (9) and then the adjustable cap (12).
12. Tighten the adjustable cap (12) until the top edge is flush with the face of the top cap (11).

## Disassembly:

**WARNING:** Relieve fluid pressure in the line before disassembling the valve.

1. Rotate adjustable cap (12) counter clockwise until the spring (10) is no longer under compression.
2. Loosen and remove clamp (13) that secures the adapter (8) to the valve body (1). Remove the adapter, spring (10), and adjustable cap (12) assembly from the valve body.
3. Remove the stem (3) and stem holder (6) from the valve body (1).
4. Slide the stem holder (6) off of the valve stem (3) and remove the stem O-ring (7).
5. Remove the body gasket (5) from the valve body (1).
6. Using a pick, hook the seat seal (2), and remove it from the stem (3).

**Note:** Seat seal (2) must be replaced after removal

## Dimensions

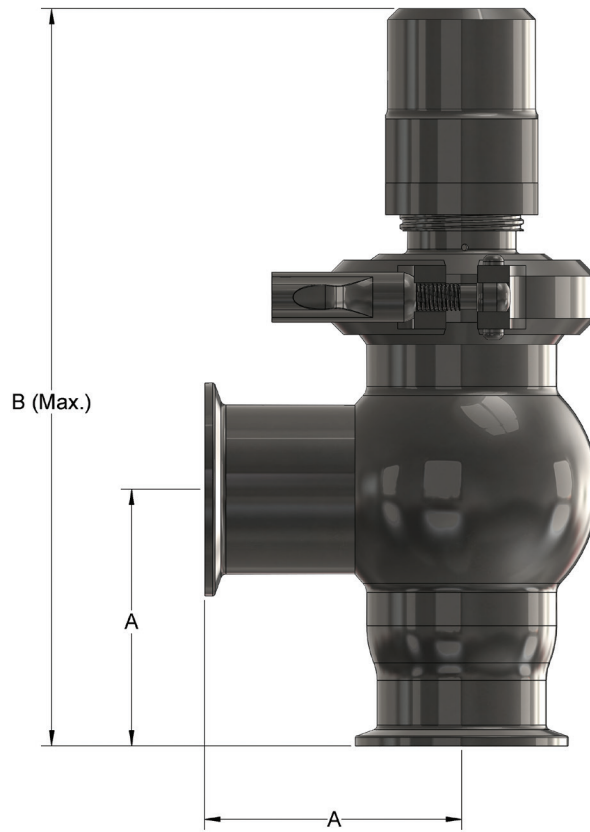

| Size | A     | B     |
|------|-------|-------|
| 1½"  | 2.69" | 9.18" |
| 2"   | 3.04" | 9.84" |

## Bill of Materials

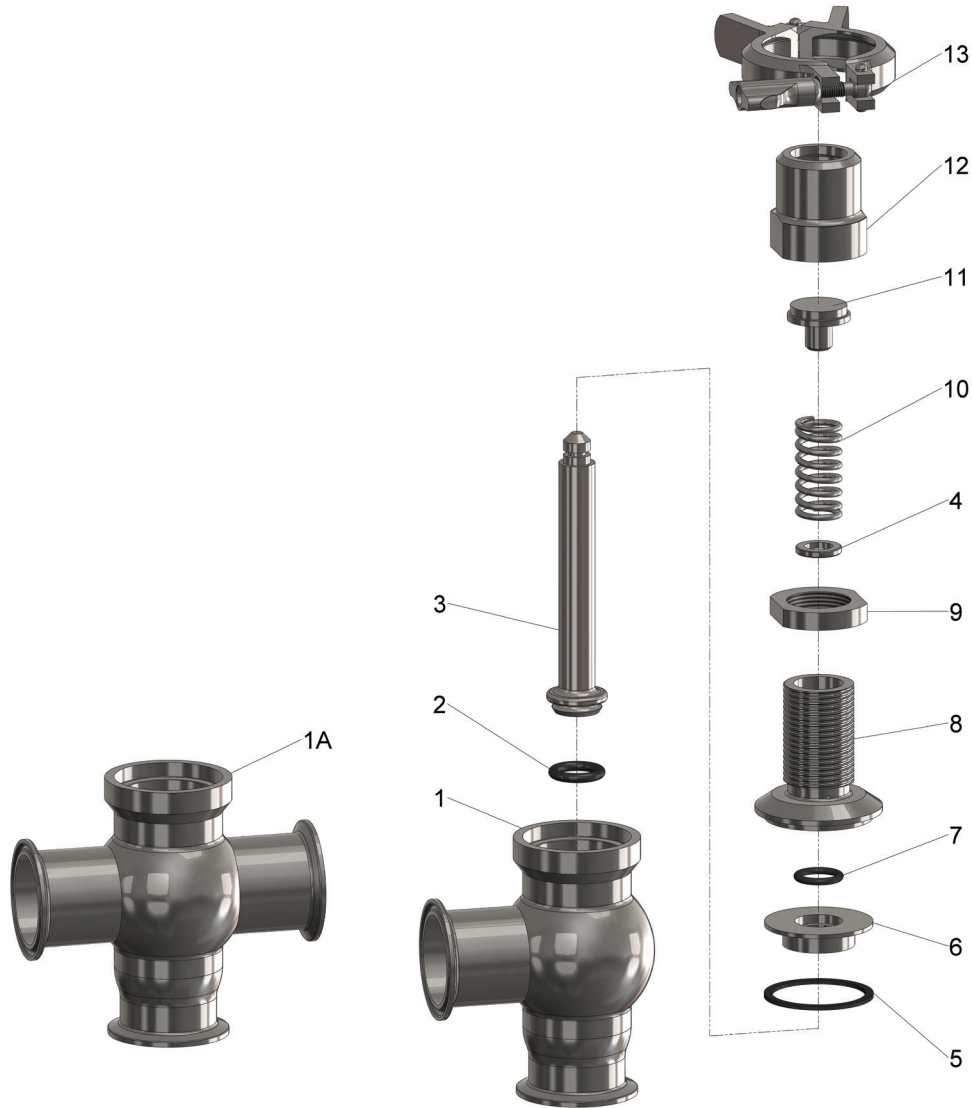

| Number | Part           | Quantity | Material   | Part Number                   |                               |
|--------|----------------|----------|------------|-------------------------------|-------------------------------|
|        |                |          |            | 1½"                           | 2'                            |
| 1      | L body         | 1        | 316L       | SPR-LBDY150                   | SPR-LBDY200                   |
| 1A     | T body         | 1        | 316L       | SPR-TBDY150                   | SPR-TBDY200                   |
| 2      | Seat seal      | 1        | FKM / EPDM | SPR-SSV / SPR-SSE             | SPR-SSV / SPR-SSE             |
| 3      | Stem           | 1        | 316L       | SPR-STEM150                   | SPR-STEM200                   |
| 4      | Washer         | 1        | 304        | SPR-WSHR                      | SPR-WSHR                      |
| 5      | Body gasket    | 1        | FKM / EPDM | 40IV150 / 40IE150             | 40IV200 / 40IE200             |
| 6      | Stem holder    | 1        | 316L       | SPR-SH150                     | SPR-SH200                     |
| 7      | Stem O-ring    | 1        | FKM / EPDM | SPR-SOV / SPR-SOE             | SPR-SOV / SPR-SOE             |
| 8      | Adapter        | 1        | 304        | SPR-ADPTR150                  | SPR-ADPTR200                  |
| 9      | Locking nut    | 1        | 304        | SPR-LN                        | SPR-LN                        |
| 10     | Spring         | 1        | 316L       | SPR-S50/SPR-S100/<br>SPR-S300 | SPR-S50/SPR-S100/<br>SPR-S300 |
| 11     | Top cap        | 1        | 304        | SPR-TOPCAP                    | SPR-TOPCAP                    |
| 12     | Adjustable cap | 1        | 304        | SPR-ADJSTCAP                  | SPR-ADJSTCAP                  |
| 13     | Clamp          | 1        | 304        | 13IL-Q100150                  | 13IL-Q200                     |

## Troubleshooting

| Problem   | Possible Cause   | Suggested Action   |
|---|--|--|
| Valve is leaking from detection port                        | Damage to stem O-ring  | Replace stem O-ring  |
| Valve is leaking between body and adapter                   | Damage to body gasket  | Inspect & replace body gasket  |
| Valve is relieving at pressures lower than the set pressure | Locking nut loose which could allow the adjustable cap to move | Tighten locking nut  |
| High pressure fluid is leaking past seat seal               | Obstruction between seal and body or damaged seat seal         | Inspect for obstructions and replace seat seal                                 |
| Valve is not stroking properly when opening                 | Washer is not installed under the spring                       | Check to make sure the washer is installed according to the assembly procedure |
| Valve will not open at all                                  | Valve is installed in an improper orientation                  | Check installation section to make sure the valve is properly oriented         |
| Any other issue   |  | Contact a Dixon Sanitary applications Engineer                                 |

## Limited Warranty

DIXON VALVE AND COUPLING COMPANY (herein called "Dixon") warrants the products described herein, and manufactured by Dixon to be free from defects in material and workmanship for a period of one (1) year from date of shipment by Dixon under normal use and service. Its sole obligation under this warranty being limited to repairing or replacing, as hereinafter provided, at its option any product found to Dixon's satisfaction to be defective upon examination by it, provided that such product shall be returned for inspection to Dixon's factory within three (3) months after discovery of the defect. The repair or replacement of defective products will be made without charge for parts or labor. This warranty shall not apply to: (a) parts or products not manufactured by Dixon, the warranty of such items being limited to the actual warranty extended to Dixon by its supplier; (b) any product that has been subject to abuse, negligence, accident, or misapplication; (c) any product altered or repaired by others than Dixon; and (d) to normal maintenance services and the replacement of service items (such as washers, gaskets and lubricants) made in connection with such services. To the extent permitted by law, this limited warranty shall extend only to the buyer and any other person reasonably expected to use or consume the goods who is injured in person by any breach of the warranty. No action may be brought against Dixon for an alleged breach of warranty unless such action is instituted within one (1) year from the date the cause of action accrues. This limited warranty shall be construed and enforced to the fullest extent allowable by applicable law.

Other than the obligation of Dixon set forth herein, Dixon disclaims all warranties, express or implied, including but not limited to any implied warranties of merchantability or fitness for a particular purpose, and any other obligation or liability. The foregoing constitutes Dixon's sole obligation with respect to damages, whether direct, incidental or consequential, resulting from the use or performance of the product.

Some products and sizes may be discontinued when stock is depleted, or may require a minimum quantity for ordering.

Dixon™, founded in 1916, is a premier manufacturer and supplier of hose couplings, valves, dry-disconnects, swivels, and other fluid transfer and control products. The company's global reach includes a wide range of products for numerous industries including petroleum exploration, refining, transportation, chemical processing, food & beverage, steel, fire protection, construction, mining and manufacturing. Dixon™'s strategic objective is to create solutions that make products safer, leak-free, longer lasting, and always available.

**dixonvalve.com • Customer Service: 800.789.1718**



*The Right Connection®*

### **Dixon Sanitary**

N25 W23040 Paul Road • Pewaukee, WI 53072

Customer Service: 800.789.1718

Fx: 800.789.4046



Dixon Website



YouTube™



f



Dixon Customer Service